

VERIFICATION OF THE MATHEMATICAL MODEL OF THE ROD ELECTRODE IN THE ELECTROSPINNING PROCESS

KOMÁREK Jiří^{1,a}, VALTERA Jan¹, SOUKUPOVÁ Julie^{2,b}, VYSLOUŽILOVÁ Lucie²,
SKŘIVÁNEK Josef¹, ŽABKA Petr¹, BERAN Jaroslav¹, LUKÁŠ David²

¹Department of textile machine design - Technical University of Liberec, Studentská 2, 460 01 Liberec, Czech Republic, ^ajiri.komarek@tul.cz

²Department of nonwovens and nanofibrous materials - Technical University of Liberec, Studentská 2, 460 01 Liberec, Czech Republic, ^bjulie.soukupova@tul.cz

Abstract

The paper deals with verification of the mathematical model of electrospinning devices. The model enables to simulate the electric field strength and voltage with using the finite element method. The simulation could be used mainly in the design of the spinning device for electrospinning process. Boundary conditions introduced into the mathematical model were obtained from an experiment on the functional model. The experiment was based on the theory of the critical potential presented by Taylor in 1969. Thanks to the FEM analysis it was found the value of the critical field strength and the place where the critical field strength appears on the polymer drop. The analysis results were compared with analytical calculation presented by Lukas in 2008. The presented mathematical model can facilitate development of the electrospinning devices. The model could be used for design optimisation of the spinning electrodes as well as the design of the whole electrospinning apparatus. Moreover, the model might be applied for setting of optimal technological parameters for producing modern nonwoven textile products.

Keywords: electrospinning, electrostatic analysis, critical field strength, spinning electrode

1. INTRODUCTION

Electrospinning is a relatively simple method for production of ultra-fine fibers (nanofibers) with a diameter ranging from a few hundred nanometers to below a micrometers, known since the beginning of the 20th century [1], [2]. Polymer solution is delivered through spinning electrode usually connected to the positive high voltage source and it is drawn and elongated by electric forces formatting nanofibers [3]. They are collected on the oppositely charged collector placed in defined distance from the spinning electrode.

There are a large number of materials and process parameters affecting the electrospinning process. This article is focused on the investigation of the influence of a rod electrode protrusion above a plate on the electrospinning process. The plate has a role of an electrical shielding and a maintaining of the homogeneous electric field. An experiment with two plate apparatus was carried out. A critical value of the applied voltage U_c and the critical field strength E_c were investigated. The electrospinning starts with reaching this critical value [4].

2. ANALYTICAL CALCULATION OF THE CRITICAL POTENTIAL AND THE CRITICAL FIELD STRENGTH

In 1964 Taylor published work which dealt with mathematical modelling of the cone shape formed by the fluid drop under the influence of an electric field [5]. This characteristic drop shape is now known as the Taylor cone.

The electrospinning occurs when overcoming a certain critical field strength. The equation describing critical field strength required to form the Taylor cone on the free liquid surface was formulated by Lukas in 2008 as

$$E_c = \sqrt[4]{\frac{4\gamma\rho g}{\varepsilon^2}}, \quad (1)$$

where γ denotes a surface tension, ρ a liquid mass density, g a gravitational acceleration and ε a permittivity of air [4].

To achieve the desired value of E_c , a certain value of potential difference between the electrodes is necessary to be set. The required value of potential difference can vary depending on the electrodes geometry, material and the device configuration. The influence of the rod electrode protrusion above the plate on the electrospinning process was researched and presented by Taylor in 1969 [6]. Based on the experiment with the two-plate apparatus, Taylor formulated the equation of the critical potential difference

$$V_K^2 = \frac{4H^2}{L^2} \left(\ln \frac{2L}{R} - \frac{3}{2} \right) (1.3\pi R\gamma)(0.09). \quad (2)$$

The distance between plates H , the protrusion of the rod electrode L and the outer radius R are expressed in cm, surface tension γ is expressed in mN/m. The factor 0.09 is inserted to give the prediction in kilovolts. Geometry of the apparatus can be seen in figure 1 left.

3. EXPERIMENT

The aim of the experiment is to examine the influence of protrusion of the rod electrode above a plate on the start of the electrospinning process. With respect to the Taylor's analysis, the experiment with axisymmetric geometry of the two-plate apparatus was set up. The steel rod electrode 2 with the outer diameter of 5 mm was protruded above a steel plate 3 with the outer diameter of 400 mm and the thickness of 2 mm. This plate was placed at a defined distance under a disc collector 1 with the same size. The reason for choosing the equal size of the plates was creation of a homogeneous electrical field for the experiments. The electrode was connected to the high voltage 5 source and positively charged. The collector was connected to the 5 source and negatively charged. A polymer drop 4 of the volume 0.05 ± 0.02 ml was applied on the top of the electrode 2 by a syringe. The apparatus was placed in the grounded protective box 6. The scheme of the experimental apparatus is shown in the figure 1 left. The real experimental apparatus is shown in the figure 1 right. The distance h between the collector 1 and the electrode 2 was kept constant 150 mm during the whole experiment. The protrusion L of the rod electrode 2 above the plate 3 was changed.

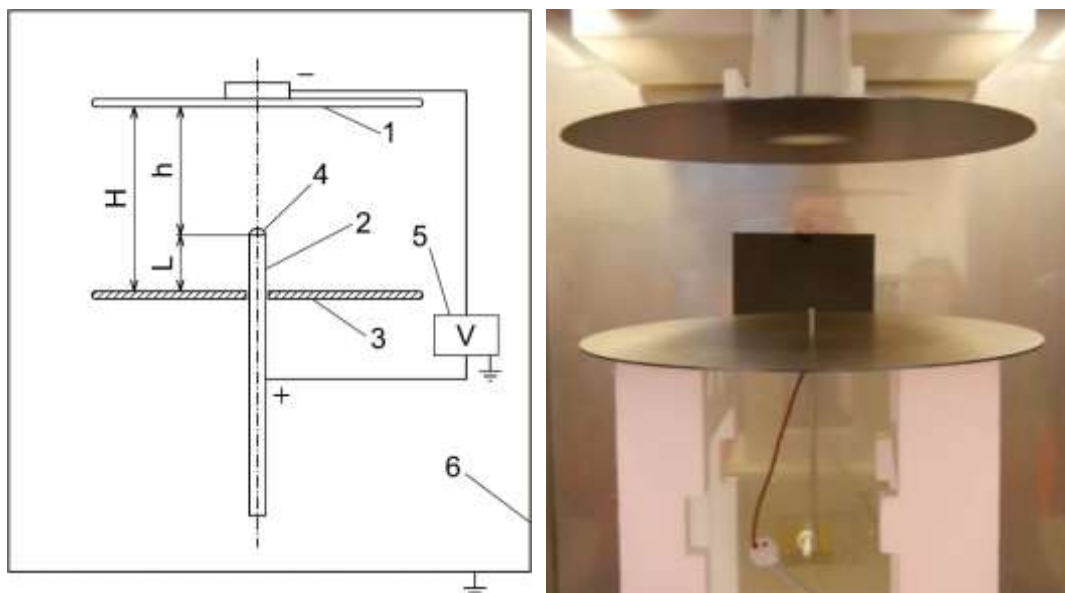

Fig. 1 Experimental apparatus

The object of this experiment was to obtain values of the critical potential for various protrusions of the rod electrode. When the potential difference reaches the critical value, the first jet appears on the polymer drop, as it is shown in the figure 2. The experiment was carried out on the device that has been designed by Taylor apparatus. It was done in order to verify the accuracy of measured data according to equations which Taylor presented in 1969 [6].

The water-soluble polyvinyl alcohol (PVA, Sloviol R16, Chemicke zavody Novaky, SK) was used for the experiments. A solution at concentration 12 wt. % was prepared dissolving in DI water. A surface tension γ of PVA solution was 40 mN/m and a liquid density ρ was 1000 kg/m³. The experiments were carried out at ambient temperature 22 °C and at a relative humidity 28 %.

Values of the critical potential were determined for 6 different settings of the rod electrode protrusion. In the first step the distance L was set. Then the polymer drop was applied on the top of the electrode. In the following step the required potential difference was set. The voltage was switched on for 10 seconds and the formation of Taylor cone was observed. After that the remained polymer drop was removed from the rod electrode. This process was repeated. The value of the input potential difference has been increased until the value of the critical potential was found. Values of the determined critical potential are shown in the table 1.



Fig. 2 Polymer drop with a polymer jet

Table 1 Measured values of the critical potential

Protrusion L [mm]	10	20	35	50	75	100
Electrode potential [kV]	38.5	30.5	22.5	20	16	13.5
Collector potential [kV]	25	18	15	12	10	10
Potential difference [kV]	63.5	48.5	37.5	32	26	23.5

4. ELECTROSTATIC ANALYSIS

For solving electrostatic tasks, the software Autodesk Simulation Multiphysics was used. The simulation mechanical software provides fast and flexible tools for calculation of boundary value problems by means of the finite element method (FEM). The mathematical model can simulate a charge distribution in an electrostatic field. The aim of the analysis was to verify the mathematical model of the electrospinning device. The verification was based on the assumption of the constant critical field strength on the polymer drop for all settings of the rod electrode protrusion.

Thanks to the axial symmetry of the two-plate apparatus, the mathematical model can be solved as a two-dimensional task with axial symmetry. The 2D geometry of the FEM model was created according to the dimensions of the two-plate apparatus described in the experiment. In the mathematical model, the geometry of the polymer drop was defined by means of spline corresponding with the drop image that was taken during the experiment and with respect of the applied solution volume 0.05 ml, as it is shown in the figure 3.

The material properties of apparatus parts were defined in the model by the relative permittivity. The critical states of electrospinning were described in the mathematical model by applied voltage corresponding to experimentally determined values of the critical potential. The applied voltage of the collector and the electrode was set in the model accordingly. The grounded protective box, was defined as a cylinder with outer diameter of 800 mm and the applied voltage of 0 V on its outer boundary.

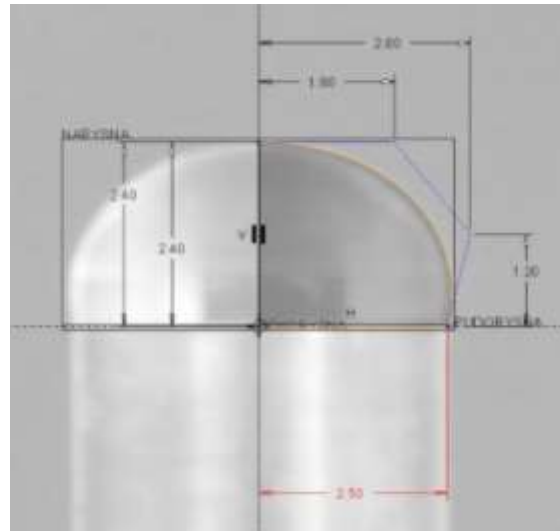

Fig. 3 Defining of the polymer drop

For the simulation the Electrostatic Field Strength and Voltage type of the analysis was selected. The voltage distribution over the model is illustrated in the figure 4. The electric field strength distribution is illustrated in the figure 5. In the detailed view the point of maximum electric field strength on the polymer drop can be observed. The place with highest electric field strength is mainly influenced by the surface curvature of the drop. The analysis shown in the figures is for the 10 mm protrusion of the rod electrode.

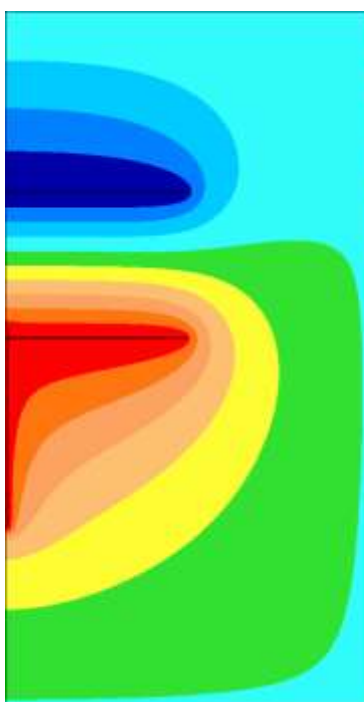

Fig. 4 Distribution of applied voltage

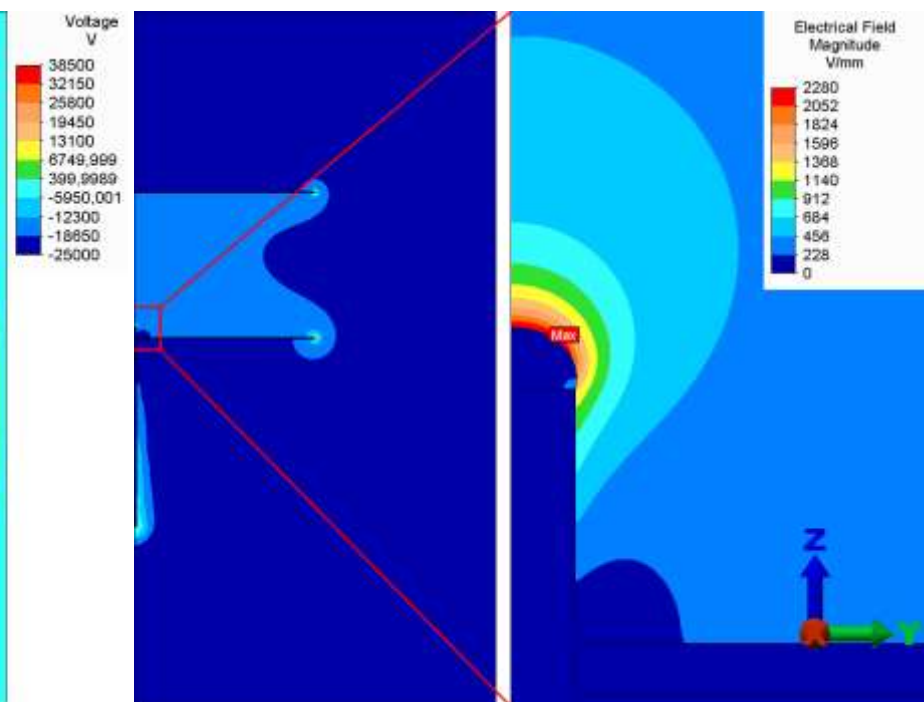

Fig. 5 Distribution of the electric field strength with a detailed view

5. RESULTS AND DISCUSSION

Measured values of the critical potential from the experiment are shown in the table 1. The figure 6 illustrates the dependence of the critical potential difference based on the electrode protrusion. The experimental results are compared with the analytical calculation (2).

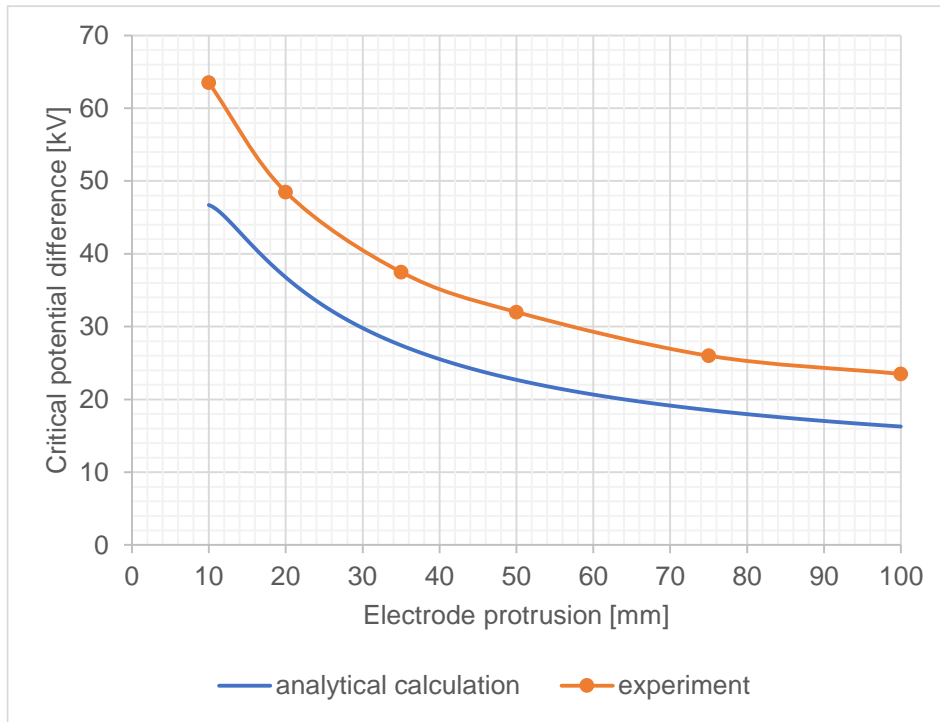

Fig. 6 Dependence of the critical potential difference based on the rod electrode protrusion

From the presented results it can be observed that the experimental and the analytical results have a similar character. The critical potential decreases while the electrode protrusion increases. However, there is a difference in the level of the potential difference. Analytical calculation is approximately 33% higher in comparison to experimental results. Dependence of the critical field strength based on the electrode protrusion is illustrated in the figure 7.

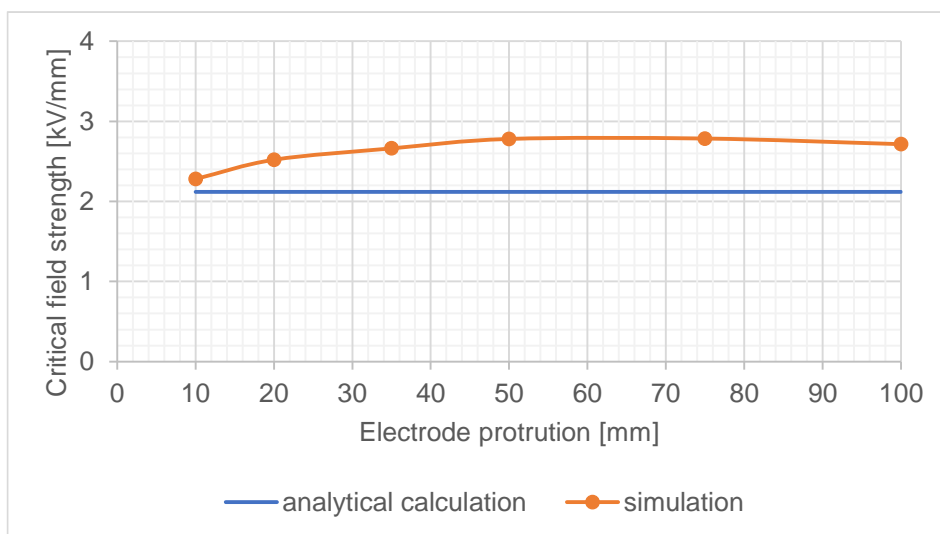

Fig. 7 Dependence of the critical field strength based on the rod electrode protrusion

In this case, the analysis results are compared with the analytical calculation based on the formula (1). The analysis results represent the maximal value of the electric field strength on the polymer drop. The value of the critical field strength by the analytical calculation (1) depends only on a polymer and therefore remains constant. The difference between the analysis results and analytical calculation is maximally 25%.

6. CONCLUSION

In order to verify the mathematical model the experiment was carried out on the two-plate apparatus with the rod electrode. The used technology consists in production nanofibres by using the rod electrode, so called electrospinning from free liquid surface. However, the mathematical model can be applied to other technologies of nanofibers production that uses the principle of electrospinning as well. The model is able to simulate a charge distribution in an electrostatic field. The knowledge obtained from the analysis can be used in the design of spinning devices, the design of new shapes of electrodes or their optimization. The model can also be applied in the search for optimal technological conditions for electrospinning process.

Dependence of the critical potential difference and the critical field strength compared in this study have a similar character. However, there is a difference in the level of compared dependencies. It may be due to the different experiment conditions. For future work, it would be appropriate to carry out additional experiments that would examine the effect the ambient environment (e.g. humidity) or boundary conditions such as the diameter of the plate or the distance of the grounded protective box from the spinning device have on the critical potential.

ACKNOWLEDGEMENTS

The results of this project LO1201 were obtained with co-funding from the Ministry of Education, Youth and Sports as part of targeted support from the "Národní program udržitelnosti I" programme.

Authors also thank the Nanoprogress z.s.p.o. to provide its laboratory for carried out experiments.

REFERENCES

- [1] FORMHALS A. Process and apparatus for preparing artificial threads. U. S. Patent No. 1 975 504, 1934.
- [2] ZELENY J. The electrical discharge from liquid points, and a hydrostatic method of measuring the electric intensity at their surface. The Physical Review, Vol. 3, Issue 3, 1914, pp. 69-91.
- [3] MOGHE A. K., GUPTA B. S. Co-axial Electrospinning for Nanofiber Structures: Preparation and Applications. Polymer Reviews, Vol. 48, Issue 2, 2008, pp. 353-377.
- [4] LUKAS D., SARKAR A., POKORNY P. Self-organization of jets in electrospinning from free liquid surface: A generalized approach. Journal of Applied Physics, Vol. 103, No. 8, 0843091-7, 2008.
- [5] TAYLOR G. Disintegration of water drops in an electric field. Proceedings of the Royal Society of London, Series A, Mathematical and Physical Sciences, Vol. 280, No. 1382, 1964, pp. 383-397.
- [6] TAYLOR G. Electrically driven jets. Proceedings of the Royal Society of London, Series A, Mathematical and Physical Sciences, Vol. 313, No. 1515, 1969, pp. 453-475.